



THE ELECTRIC RANGE

# GOOD LOOKS THAT DON'T COST THE EARTH

The traditional cooking range, with its hand-crafted good looks and quality cooking, epitomises a relaxed, homely lifestyle in town or country. The Everhot offers all this, and far more, at a cost that is astonishingly down to earth.

The Everhot is an electric heat storage cooking range that simply plugs into a 13 amp socket, and needs no flue or concrete base. With a choice of sizes that make it easy to position alongside your standard kitchen units, it gives you all the control and versatility of modern cooking methods, together with the even baking and winter warmth of the traditional range. The standard full width grill in the upper oven is another of its many advantages over other comparable ranges. To top it all, the Everhot averages less than half the running costs of most other traditional ranges. Not surprisingly, for more than 20 years, Everhot has been the choice of thousands of delighted owners across the country.

The Everhot is a true heat storage range and is therefore designed to provide both cooking and room heat.

## ENERGY SAVING

With its unique, energy saving design, the Everhot has extremely low energy requirements, so you can plug it into a 13 amp socket. The Everhot is quite simply the economy leader among heat storage ranges, with a miserly consumption of 88 units per week when run at normal working temperature. This means that at 10p per unit the cost of running will be around £9 per week.

## EASY TO INSTALL

Because it runs on electricity, the Everhot needs no flue. Although it is incredibly solid and built to last a lifetime, its weight will not usually require the kitchen floor to be reinforced. So installation is straightforward, and when you move, your Everhot can move with you.

## THE CRAFTSMAN'S TOUCH

Each Everhot cooker is individually hand-built, down to the oak or beech door handles, the traditional rope seals and the heavy-duty spring-loaded lid. Every cooker is robust, reliable and has all the classic finishing touches that you would expect.



COALEY MILL



EVERHOT 90 IN BURGUNDY



THE EVERHOT IS PARTICULARLY SUITABLE FOR SUSTAINABLE ENERGY PROJECTS



## ELEGANCE & VERSATILITY

The four models in the Everhot range are available in a choice of colours that enable them to integrate with your kitchen colour scheme while providing all the control and versatility of modern cooking appliances.

# WHATEVER THE STYLE OR SIZE OF YOUR KITCHEN, THERE IS AN EVERHOT TO FIT

If you love the idea of a traditional cooking range but think that your kitchen's compact proportions may not accommodate it – think again. The **Everhot 60** fits neatly into a standard 600mm wide kitchen unit. With no flue and no reinforced floor needed, installation is easy. What's more, you can take those spacious top and bottom ovens, four-saucepan hot and simmer plates and integral grill with you when you move on.

The **Everhot 90** was designed for people who want a bigger presence in their kitchen than that of the most compact model. It is also a perfect solution if an old range has been removed; most were built to this 900mm size, so the Everhot 90 can effortlessly fill the gap. In addition to all the traditional appeal and versatility of an Everhot, the 90 features a useful resting place on the side of the hotplate – ideal for a joint of meat, or for preparing food before adding it to a pan on the hotplate. The control box is integral and is neatly packaged behind its own door.

The **Everhot 120** doubles the benefits of the 60. Enjoy four ovens and two twin hotplates, each independently adjustable for maximum versatility. So you can have cakes in one oven, the roast vegetables in another, the joint in a third and a warming oven, all at different temperatures. On the hotplates, a sauce simmering gently, peas boiling on another – with loads more hotplate space to spare.

The **Everhot 150** extends the brilliant versatility of the 120 with integral control boxes, and a useful resting plate positioned between the hotplates.

The classic appeal of all models can be tailored to the look you want for your kitchen, with a choice of colours and optional beech handles instead of the standard oak. Everhot fits the kitchen and fits the bill.



EVERHOT 60 IN BLUE



# THE LIFELONG INVESTMENT YOU'LL FALL IN LOVE WITH

You'll love the Everhot because of its roots in a tradition of craftsmanship and very green fuel efficiency. It's ahead of its time, originally developed more than 20 years ago for people able to draw power from limited renewable resources. Innovatively designed to run at a constant temperature 24/7, and to plug into a simple 13 amp socket, it minimises power consumption and wastage while maximising performance and versatility.

Made at Coaley Mill, a 13th century water-powered mill in the old wool heartland of the south Cotswold valleys, the Everhot is produced using energy generated from a state-of-the-art, environmentally friendly water turbine. So while you enjoy cooking delicious food using the Everhot's versatility, you can be confident that you're using a cooking appliance that leads the field; from the start of the build process to the ongoing running costs. Furthermore, because of the ease of installation, your Everhot can be with you in any home you choose – lifelong.



EVERHOT 150 IN CREAM



EVERHOT 90 IN GREEN

# 'THE COOK'S COOKER', CHOSEN BY THE COTSWOLD CHEF

## A PASSION FOR COOKING

Rob Rees MBE is one of the UK's leading chefs and also a man who is committed to creating a revolution in the food culture of Britain. Based in the Cotswolds in Gloucestershire, an area renowned for its home-grown food production, Rob is a champion of good food and good cooking. He wholeheartedly endorses the Everhot as 'the cook's cooker', and embraces the company's green credentials:

*"Everhot – a family company based locally near Dursley who manufacture the oven on electricity naturally generated by the water mill is without a shadow of a doubt my preferred choice. In fact so much so that we bought two of them. It runs off a normal 13 amp fuse, has top plates and ovens that can be centred on your cooking, rather than you having to adapt your cooking to the oven's needs. It is efficient to run and will grace a country or town kitchen with style, charisma and gentle elegance. Watch this space as the Everhot becomes established as the Cotswold Chef's choice and indeed that of professional and domestic cooks around the UK."*



## SOMETHING'S COOKING IN THE KITCHEN!

Rob is the former owner of a Michelin starred restaurant, however these days his role is more of a food consultant – he spends a great deal of time and energy in the promotion of UK foods worldwide. He has recently been awarded the MBE for these efforts.

A perfectionist himself, he values the perfect balance of the Everhot in its efficiency, versatility and energy saving qualities. So you'll often find Rob exercising his creativity with yet another unique culinary masterpiece, all brought to life effortlessly with the Everhot.



## ADD A SPLASH OF COLOUR

Whatever your kitchen style, Everhot have a colour to complement it.



EVERHOT 90 IN BLACK



## CONTEMPORARY & CLASSIC

Robustly built good looks that will fit into any kitchen space. The Everhot's four models give you the choice, versatility and style to perfect your kitchen and your cooking.

# WHAT'S HOT ABOUT EVERHOT?

## EASE OF INSTALLATION

No major upheavals needed, no floors needing to be reinforced, no flue to be installed and runs off a 13 amp socket. Every Everhot range can fit quickly and easily into your kitchen, whether the space available is 600mm, 900mm, 1200mm or 1500mm.

## TOTAL CONTROL

Each oven and heating surface can be independently adjusted to the temperature you require. The grill, a rare feature among other comparable ranges, is also independently adjustable. If a particular cooking area is not needed for long periods, you can switch it off or turn it down without affecting the other areas. So on hot summer days, you don't have to roast in the kitchen, unlike other leading brands.

## ECONOMICS

The Everhot 60 and 90 are the economy leaders among heat storage ranges, consuming a mere 88 units of power per week when set at normal cooking temperatures.

## LIFETIME INVESTMENT

When you move, your Everhot can move with you. Our product is beautifully engineered and will, quite literally, last a lifetime.

## MAINTENANCE-FREE

With a little care and affection, your Everhot will perform trouble-free year after year, with no annual servicing requirement (unlike other ranges). When considered over a lifetime of ownership, this represents a considerable cost saving.



EVERHOT BURGUNDY OAK HANDLE



EVERHOT BLUE DOOR HINGE



EVERHOT CREAM HAND RAIL

# CREATE YOUR PERFECT RANGE

## COLOURS

A carefully selected colour range offers you abundant choice for your kitchen. From understated Black, dark Blue or Green to rich Burgundy or cool Cream, there's a colour for every kitchen theme. Whatever your choice, the Everhot will always be the star presence in your kitchen.



EVERHOT BLACK OAK HANDLE



EVERHOT BURGUNDY OAK HANDLE



EVERHOT CREAM OAK HANDLE



EVERHOT BLUE OAK HANDLE



EVERHOT GREEN OAK HANDLE

## OPTIONS

Wood has always been the natural choice for Everhot handles, because it doesn't get hot and is easy to grip. We offer both traditional hand crafted oak handles or a more contemporary beech handle. You can also specify where you would like the Everhot logo to appear, with plain or embossed doors and an optional etched control panel logo.



BEECH HANDLE/PLAIN DOOR (OPTIONAL)



BEECH LID HANDLE (OPTIONAL)



ETCHED CONTROL PANEL LOGO (OPTIONAL)



## HEART OF THE HOME

With its gentle background  
warmth your Everhot will become  
the heart of your kitchen.

# SPECIFICATIONS



- A Oak handles
- B Spring-loaded lid
- C Cast iron hot and simmer plates with durable stainless steel surround
- D 2.5KW full-width radiant grill, which can also be used to rapidly boost oven temperature
- E Removable stainless steel shelves with variable height options
- F Two large ovens
- G Cast iron doors with oak handles



THE STAINLESS STEEL CONTROL BOX FITS NEATLY INTO AN ADJOINING CUPBOARD

## FUEL TYPE

Electric – 13 amp supply.

The 120 and 150 require 2 separate supplies.

## SERVICING

No regular servicing is required – a saving against other brands.

## BACKGROUND WARMTH

When operated at our recommended working temperatures, the 60 and 90 will produce approximately 500W of heat – the 120 and 150 as much as 1KW.

## ENERGY CONSUMPTION

The 60 and 90 consume approximately 88 units of power when used at recommended settings. The 120 and 150 ranges will consume approximately double this figure – if you choose to utilise all the available cooking space.

## COOKING AREA

Hot plate: W225mm, D355mm

Simmer plate: W175mm, D355mm

Top oven: W395mm, H290mm, D490mm

Bottom oven: W395mm, H290mm, D470mm

*Note: The Everhot 120 and 150 ranges provide two sets of hot/simmer plates and four ovens.*

## TEMPERATURE CONTROL

Hot plate: Maximum 400C

Simmer plate: Maximum 400C

Top oven: Maximum 250C

Bottom oven: Maximum 200C

Grill: A 2.5KW full width radiant grill with a 30 minute digital timer is located in the top oven.

## TIME TO TAKE CONTROL

Our digital control box allows temperatures to be set at each of the cooking areas. The control box also provides the facility to turn off parts of the cooker when not required.

*Note: The Everhot is a cooking range which also provides kitchen warmth.*

## ENERGY EFFICIENT APPLIANCE

Typical running costs approximately £9.00 per week at 10p Kwhr. Based on 88 units/week.

*Typical consumption when used at recommended settings.*

60

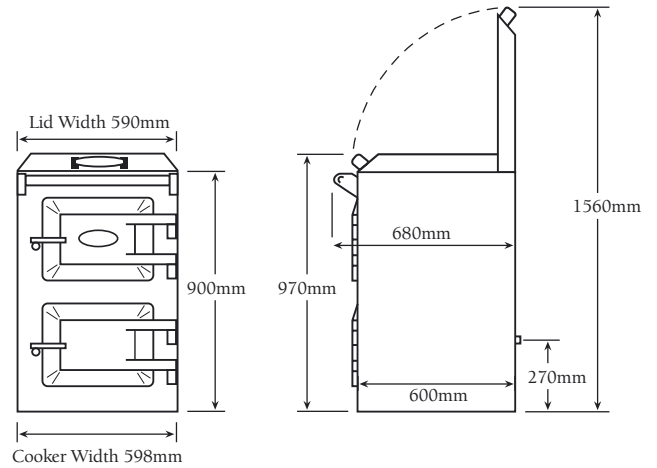

90

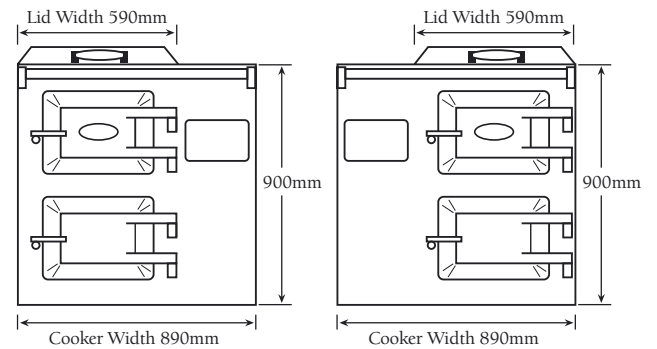

120

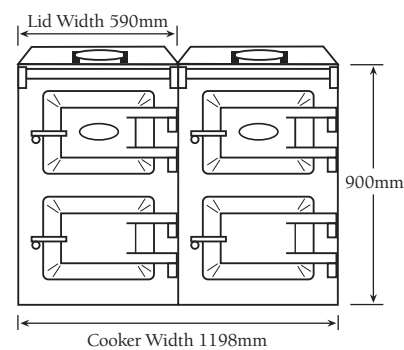

150

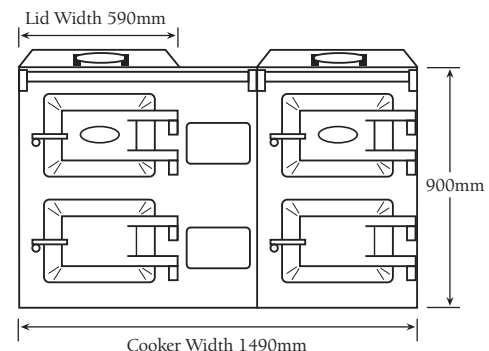



Everhot Cookers  
Coaley Mill, Coaley, Dursley,  
Gloucestershire GL11 5DS  
Tel: 01453 890018  
Fax: 01453 890958  
Email: [sales@everhot.co.uk](mailto:sales@everhot.co.uk)  
[www.everhot.co.uk](http://www.everhot.co.uk)